

EL Series

Power Failure Lighting &
Egress Path Marking
Energy Controls

PRODUCT FEATURES

- Provides light throughout the home, office, school, hotel, etc. during power outages
- Night light feature provides sufficient light down hallways and throughout rooms late at night
- While still providing the same features, the EL300 Series effectively replaces a 15 Amp single-pole switch and the EL200 Series effectively replaces a 15 Amp receptacle
- Commercial grade models interface to Fire & Smoke Alarm products
- EL500E includes Chevron design for egress direction

APPLICATIONS

- Residential Homes
- Schools
- Offices
- Retail Stores
- Hotels
- Restaurants
- Apartments

SPECIFICATIONS

Voltage: 120 VAC or 120-277 VAC*

Style: Flushmount design

Light Source: 3 high output LEDs

EL200 & EL300 Series Color: White, Ivory & Light Almond

Agency Approval: 

Warranty: 1 year

* Option for select models.



EL100 – In-Wall Power Failure Light



Specifications:

- **Voltage:** 120 Volts 60 Hz.
- **Light Source:** 3 High Output White LEDs
- **Features:** Night Light Mode, Battery Test Switch
- **Battery Life:** 4 hours minimum
- **Color:** Clear Lens

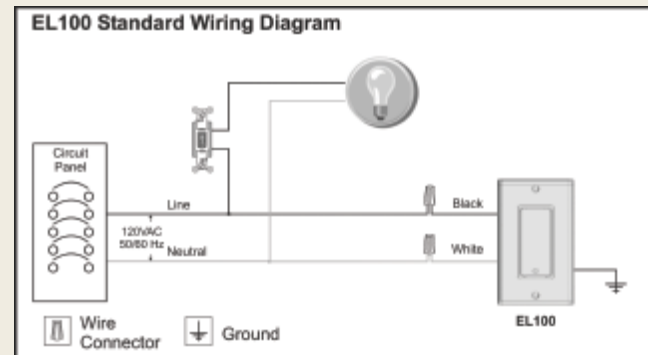

EL200 Series – In-Wall Power Failure Light w/15 Amp Receptacle



Models: EL200, EL200W and EL200A

Specifications:

- **Voltage:** 120 Volts 60 Hz.
- **Light Source:** 3 High Output White LEDs
- **Features:** Night Light Mode, Battery Test Switch, 15 Amp Receptacle
- **Battery Life:** 90 minutes minimum
- **Color:** White, Ivory & Light Almond w/Clear Lens

Model#	Volts 60Hz	Color
EL200	120	Ivory
EL200W	120	White
EL200A	120	Light Almond

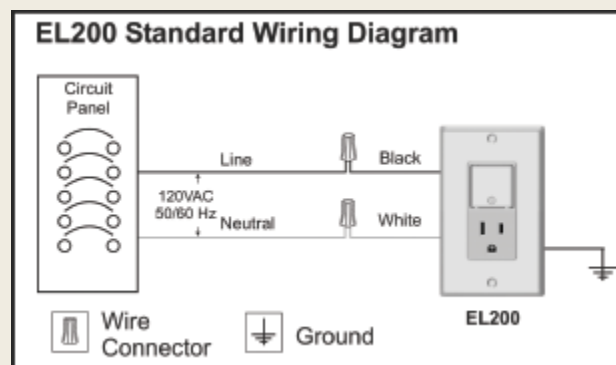

EL300 Series – In-Wall Power Failure Light w/15 Amp Single-Pole Switch



Models: EL300, EL300W and EL300A

Specifications:

- **Voltage:** 120 Volts 60 Hz.
- **Light Source:** 3 High Output White LEDs
- **Features:** Night Light Mode, Battery Test Switch, 15 Amp Single-Pole Switch
- **Battery Life:** 90 minutes minimum
- **Color:** White, Ivory & Light Almond w/Clear Lens

Model#	Switch	Color
EL300	Single-Pole	Ivory
EL300W	Single-Pole	White
EL300A	Single-Pole	Light Almond

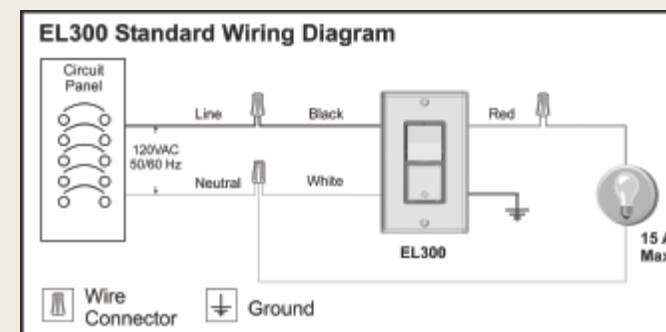

EL500 – Commercial Grade In-Wall Light



Specifications:

- **Voltage:** 120 VAC, 277 VAC option
- **Light Source:** 3 High Output White LEDs
- **Features:** Battery Test Switch, Flasher Interface to Fire & Smoke Alarm products, Meets UL1994 for egress lighting
- **Battery Life:** 4 hours minimum
- **Color:** Clear Lens

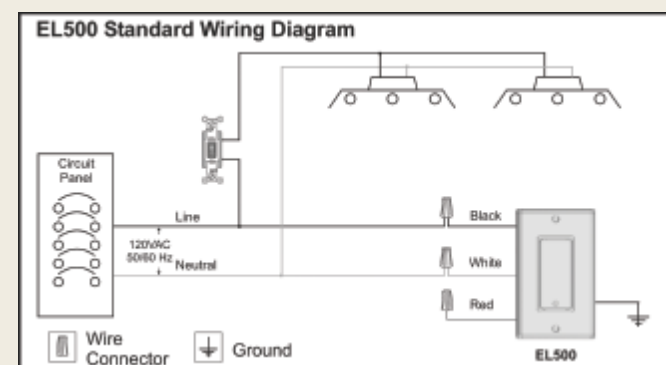

Don't Be Caught in the Dark

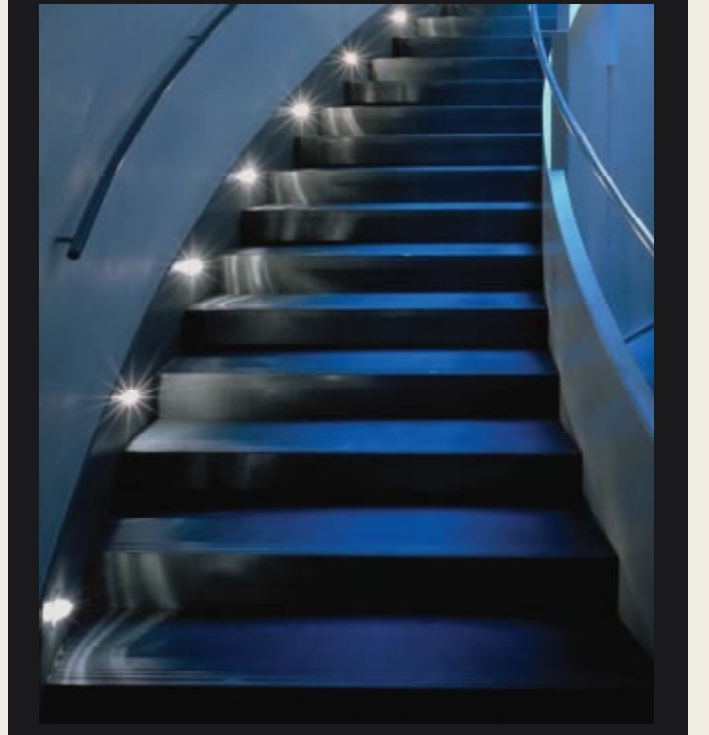

EL500E – Commercial Grade In-Wall Egress Light



Specifications:

- **Voltage:** 120 VAC, 277 VAC option
- **Light Source:** 3 High Output Red LEDs in Chevron design for egress direction
- **Features:** Battery Test Switch, Flasher Interface to Fire & Smoke Alarm systems, Meets UL1994 for egress path marking
- **Battery Life:** 4 hours minimum
- **Color:** Red Chevron Lens

